

MHS 501-SUPER

with cascade cooling system
water-cooled

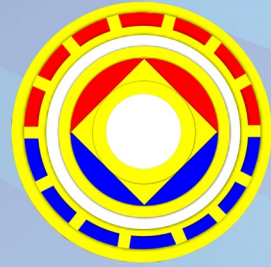

500 Amp./100% duty cycle (CO₂)
450 Amp./100% duty cycle (mixed gas)

Spare parts like:
MHS 35-D gas-cooled

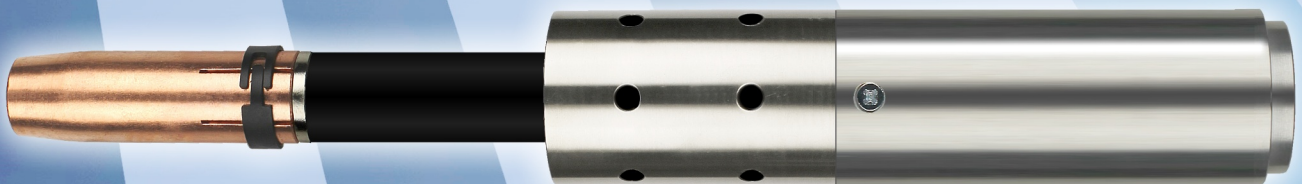

MHS 501- SUPER with cascade cooling system

water-cooled



Gas nozzle conical ID14mm
part No. 50193201



Gas nozzle conical ID16mm
part No. 50193001



Gas nozzle cylindrical ID19mm
part No. 50193301

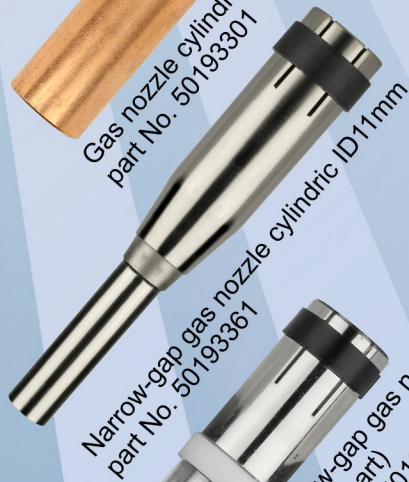

Narrow-gap gas nozzle cylindrical ID11mm
part No. 50193361

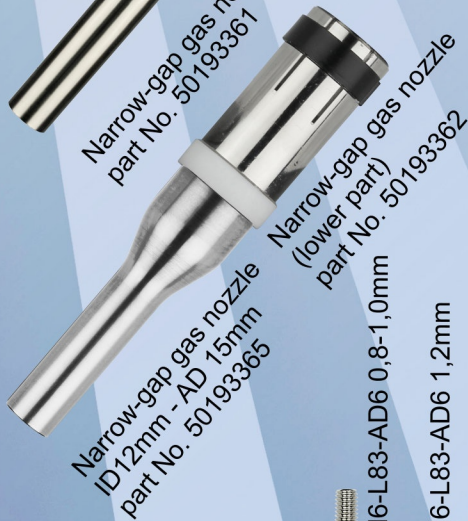

Narrow-gap gas nozzle (lower part)
part No. 50193362

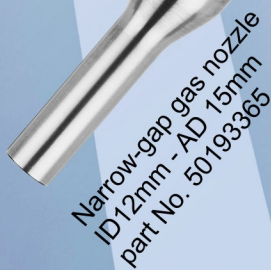

Narrow-gap gas nozzle ID12mm - AD 15mm
part No. 50193365



Narrow-gap contact tip M6-L83-AD6 0,8-1,0mm
part No. 68310101

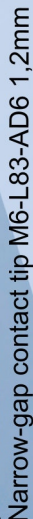

Narrow-gap contact tip M6-L83-AD6 1,2mm
part No. 68312101



Socket for centering the narrow-gap contact tip
part No. 91921801



Narrow-gap contact tip M8-L85,5-D10 drilled to 6mm 1,2 mm
part No. 88551241



Contact tip M8 x 30
part No. 830□001
part No. 830□401(CuCrZr)
part No. 830□301(nickel plated)
□ Please fill in wire diameter

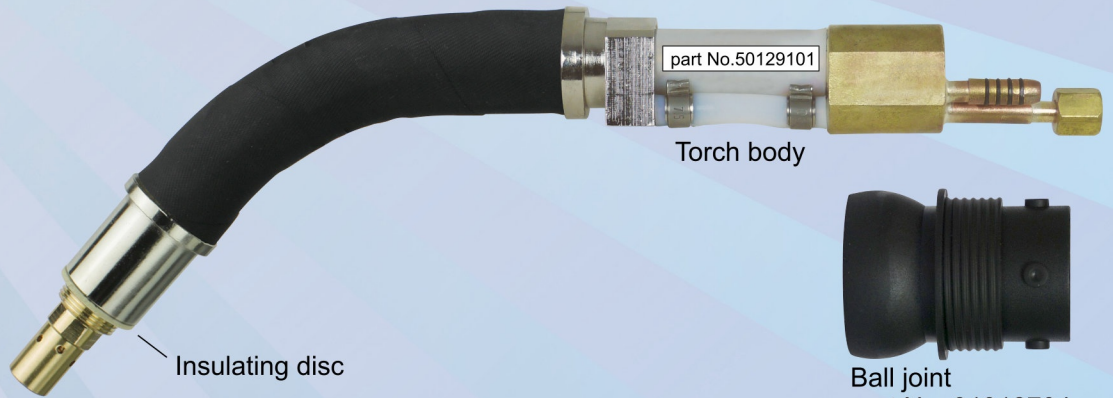

part No.50129101

Torch body

Insulating disc



Ball joint
part No. 91912704



Ratio-handle with ball joint
part No. 91912537



Industry-handle with ball joint
part No. 91912104

Insulating disc
part No. 50191241



Contact tip holder IG-M8
part No. 50198001



Contact tip holder IG-M6 for narrow-gap contact tip
part No. 50198101

Gas diffusor
part No. 50191201



Ceramic-gas diffusor
part No.50191203

HSN 669-1



MHS 501-SUPER with cascade cooling system

500 Ampere at 100% duty cycle (CO₂) - 450 Ampere at 100% duty cycle (mixed gas)

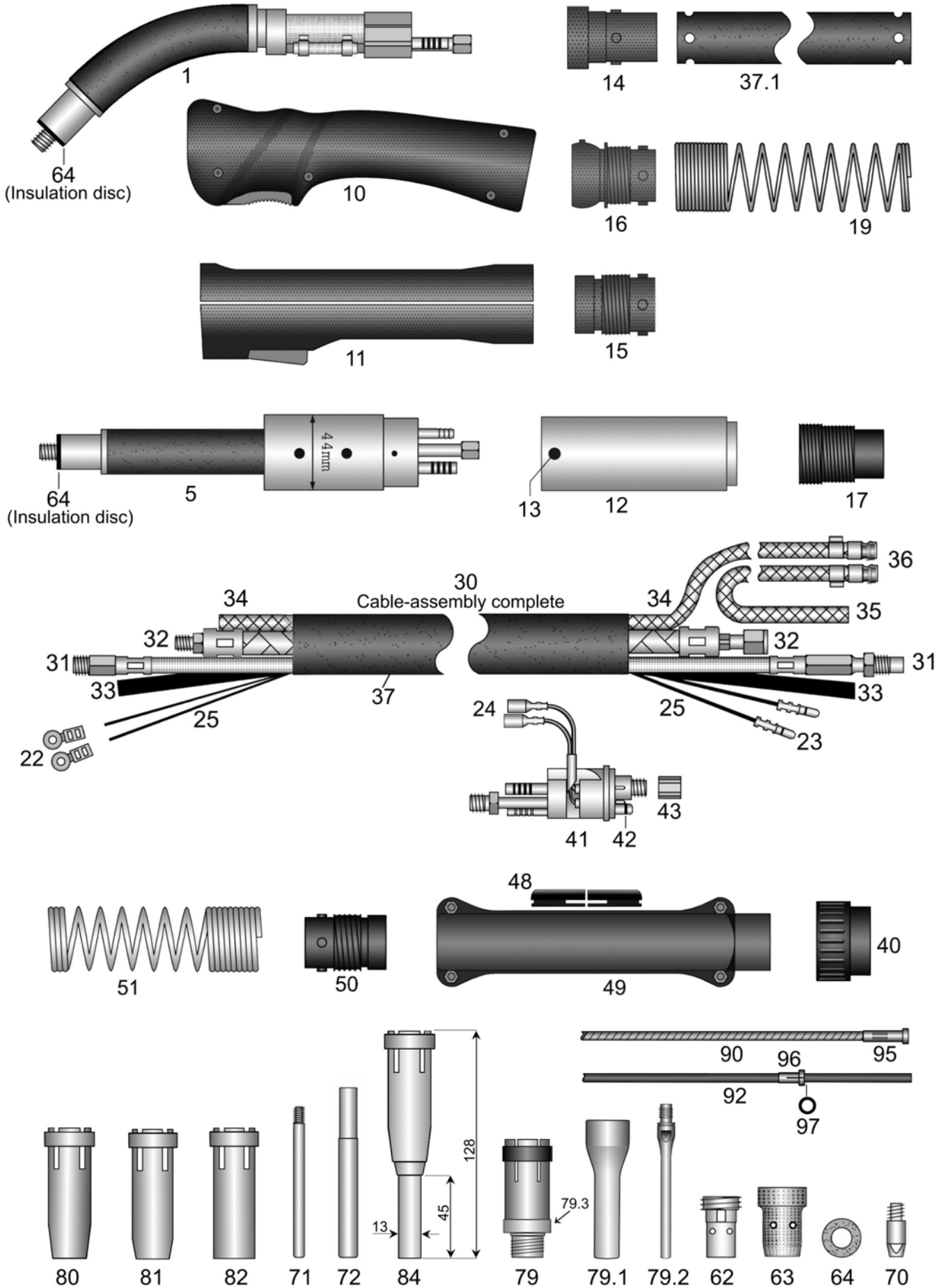

HSN 136-1

MHS 501-SUPER

Welding-torch MIG-MAG water-cooled

500A at 100% duty cycle (CO2) - 450A at 100% duty cycle (mixed gas)

Art.-No.

Spare parts as torch MHS 35-D gas-cooled

50120311	Torch MHS 501-SUPER / 3m EURO central adapter
50120411	Torch MHS 501-SUPER / 4m EURO central adapter
50120511	Torch MHS 501-SUPER / 5m EURO central adapter
50125311	AUTomatic-torch MHS 501-SUPER / 3m EURO central adapter

NEW with short torch body (-30mm)

50130311	Torch MHS 501-SUPER short torch body (-30mm) / 3m EURO central adapter
50130411	Torch MHS 501-SUPER short torch body (-30mm) / 4m EURO central adapter
50130511	Torch MHS 501-SUPER short torch body (-30mm) / 5m EURO central adapter

**For torches without EURO central-adapter the following prices apply.
Please note that for some special machine side connections surcharges may arise,
which you will find in the appendix "A" custom made products.**

50120301	Torch MHS 501-SUPER / 3m
50120401	Torch MHS 501-SUPER / 4m
50120501	Torch MHS 501-SUPER / 5m
50125301	AUTomatic-torch MHS 501-SUPER / 3m

NEW with short torch body (-30mm)

50130301	Torch MHS 501-SUPER short torch body (-30mm) / 3m
50130401	Torch MHS 501-SUPER short torch body (-30mm) / 4m
50130501	Torch MHS 501-SUPER short torch body (-30mm) / 5m

**Special lengths for hand- and AUTomatic-torches
please notice appendix "B".**

**Torches with flexible and highly heat resistant cable assemblies available for small
surcharges! Please see appendix "B"**

29004602	Surcharge: Torch body with custom bending
91900102	Adapter EURO central adapter fits power source with Dinse central adapter

**Torch bodies and AUTomatic torch bodies with 2 circuit cooling (Cascade cooling system),
complete with contact tip holder M8 and insulator disc.**

1	50129101	Torch body MHS 501-SUPER
N.i.	50139101	Torch body MHS 501-SUPER short version (-30mm)
5	50129151	AUTomatic-torch body MHS 501-SUPER

**Handles complete with switch and screws
Ball joints or sockets are also included**

10	91912537	Ratio-handle 21mm with ball joint
10	91912437	Ratio-handle 21mm (**without ball joint**)
N.i.	91912438	Ratio microswitch DC2
N.i.	91912439	Push button red for Ratio handle also fits RAUCH handle
N.i.	91912441	Spring fits button Ratio grip handle and RAUCH grip handle
11	91912104	Industry-handle 21mm with ball joint
11	91912433	Industry-handle 21mm (**without ball joint**)
N.i.	91920412	Switch-set fits industry-handle for 21mm (9 parts)
N.i.	91920702	Screw M3x11,5mm fits Ratio/Industry/RAUCH handle and cable support

MHS 501-SUPER

Welding-torch MIG-MAG water-cooled

500A at 100% duty cycle (CO2) - 450A at 100% duty cycle (mixed gas)

Art.-No.		
N.i.	91920703	M3 mounting socket fits Ratio/Industry/RAUCH handle and cable support
12	91912923	AUT handle tube, aluminium-cladded AD44mm
13	91912912	Counter sunk bolt M4x6mm for AUT handle tube OD44mm
14	50191251	Rubber cable-support RETRO
15	91912701	Spring socket pistol side fits handle without ball joint
16	91912704	Spring socket pistol side fits handle with ball joint
17	91912711	AUT spring socket
19	91912501	Cable support spring pistol-side fits water-cooled torches
N.i.	91912511	AUT cable support spring (long design)
N.i.	91912521	AUT suspension spring
N.i.	91912531	AUT carabiner
N.i.	10089001	Single stroke button (rubber)
22	91902811	Cable-plug fits industry-handle
23	91902901	Male connector cable-plug for machine side EURO central adapter
24	91903001	Female connector cable-plug fits machine side EURO central adapter
25	91902423	Meter control line 2x0,75mm ² red free of halogen (100m)
Spare cable-assemblies complete with cable support springs and fittings. Fits handles with or without ball joint - please specify!		
30	09200312	Spare cable assembly 3m / without EURO central adapter
30	09200412	Spare cable assembly 4m / without EURO central adapter
30	09200512	Spare cable assembly 5m / without EURO central adapter
Supply lines and thermo-hoses, superflexible and highly heat resistant please see appendix "C" and "D"		
31	0950a311	Wire conduit flexible MHS / 3m EURO central adapter (flexible)
31	0950a411	Wire conduit flexible MHS / 4m EURO central adapter (flexible)
31	0950a511	Wire conduit flexible MHS / 5m EURO central adapter (flexible)
32	09400311	ST 80 PVC-NIT power/water cable MHS / 3m EURO central adapter
32	09400411	ST 80 PVC-NIT power/water cable MHS / 4m EURO central adapter
32	09400511	ST 80 PVC-NIT power/water cable MHS / 5m EURO central adapter
Supply lines for AUTomatic torches.		
31	0950d311	AUT wire conduit MHS / 3m EURO central adapter white (hard)
32	09400313	HT 110 rubber fabric hose power/water cable MHS / 3m EURO central adapter
Reel goods: Prices are per meter and only applicable if a complete reel is purchased.		
33	41500001	Meter ST 70 PVC hose ID4,0-W1,5mm black for gas (100m)
34	50170001	Meter ST 80 PVC-NIT fabric hose ID5,0-W1,7mm blue for water (100m) robust model, thick-walled and non-buckling
35	50171001	Meter ST 80 PVC-NIT fabric hose ID5,0-W1,7mm red for water (100m) robust model, thick-walled and non-buckling
36	91901001	Cooling liquid plug nipples EURO
N.i.	91901008	Closing cap blue fits cooling liquid plug nipples EURO

MHS 501-SUPER

Welding-torch MIG-MAG water-cooled

500A at 100% duty cycle (CO2) - 450A at 100% duty cycle (mixed gas)

Art.-No.		
N.i.	91901009	Closing cap red fits cooling liquid plug nipples EURO
37	25151001	Meter rubberized fabric protective hose ID25-W1,5mm (40m)
37.1	25151311	Rubberized fabric protective hose ID25-W1,5mm perforated fits 3m / EURO central adapter
37.1	25151411	Rubberized fabric protective hose ID25-W1,5mm perforated fits 4m / EURO central adapter
37.1	25151511	Rubberized fabric protective hose ID25-W1,5mm perforated fits 5m / EURO central adapter
40	91900701	Terminal nut insulated fits EURO central adapter
41	91900201	Central adapter fixed contact-pins EURO central adapter
41	91900206	Central adapter spring contact-pins EURO central adapter
42	91900801	O-ring ID4-W1mm fits gas-nipple EURO central adapter
43	91900901	Swivel nut IT-M10x1 (rounded edges) fits EURO central adapter
48	91901011	Rubber-hose-fence fits cable support
49	91900561	Cable support machine side (screws included) fits EURO central adapter
N.i.	91920702	Screw M3x11,5mm fits Ratio/Industry/RAUCH handle and cable support
N.i.	91920703	M3 mounting socket fits Ratio/Industry/RAUCH handle and cable support
N.i.	91900601	Attachment screw M4x6mm fits cable support EURO central adapter
50	91912801	Spring-socket fits cable support
51	91912601	Cable support spring
62	50198001	Contact tip holder IT-M8 AG-M16x1-L25mm
62	50198101	Contact tip holder IT-M6 AG-M16x1-L25mm (for narrow-gap contact tip M6)
63	50191201	Gas diffusor Keripol white
63	50191204	HT-gasdiffusor black power
63	50191203	Ceramic-gas diffusor
N.i.	50191243	Narrow gap-insulation ring black power
64	50191241	Insulator
70	83008001	Contact tip M8-L30-AD10 0,8
70	83010001	Contact tip M8-L30-AD10 1,0
70	83012001	Contact tip M8-L30-AD10 1,2
70	83014001	Contact tip M8-L30-AD10 1,4
70	83016001	Contact tip M8-L30-AD10 1,6
70	83020001	Contact tip M8-L30-AD10 2,0
70	83010401	Contact tip M8-L30-D10 CuCrZr 1,0
70	83012401	Contact tip M8-L30-D10 CuCrZr 1,2
70	83014401	Contact tip M8-L30-D10 CuCrZr 1,4
70	83016401	Contact tip M8-L30-D10 CuCrZr 1,6
70	83020401	Contact tip M8-L30-D10 CuCrZr 2,0
70	83008301	Contact tip M8-L30-AD10 0,8 nickel-plated
70	83010301	Contact tip M8-L30-AD10 1,0 nickel-plated
70	83012301	Contact tip M8-L30-AD10 1,2 nickel-plated
70	83014301	Contact tip M8-L30-AD10 1,4 nickel-plated
70	83016301	Contact tip M8-L30-AD10 1,6 nickel-plated
70	83008a01	Contact tip M8-L30-D10 0,8-A for aluminium wire
70	83010a01	Contact tip M8-L30-D10 1,0-A for aluminium wire
70	83012a01	Contact tip M8-L30-D10 1,2-A for aluminium wire

MHS 501-SUPER

Welding-torch MIG-MAG water-cooled

500A at 100% duty cycle (CO2) - 450A at 100% duty cycle (mixed gas)

Art.-No.		
70	83016a01	Contact tip M8-L30-D10 1,6-A for aluminium wire
Another 2-part narrow gap system with curved gas nozzle can be combined with this torch type! Prices on request		
71	68310101	Narrow-gap contact tip M6-L83-AD6 0,8-1,0 nickel-plated
71	68312101	Narrow-gap contact tip M6-L83-AD6 1,2 nickel-plated
72	91921801	Narrow-gap centering wrench for contact tip M6-L83-D6mm
79	50193362	Narrow gap-gasnozzle lower part, nickel-coated with PTFE insulation ring
79.1	50193364	cylinder (nickel plated) for narrow gap-gasnozzle ID11-AD14mm fits lower part
79.1	50193365	cylinder (nickel plated) for narrow gap-gasnozzle ID12-AD15mm fits lower part
79.2	88551241	Narrow gap-contact tip M8-L85,5-D10 turned down to 6mm 1,2 CuCrZr
79.3	50193363	PTFE-seal fits narrow gap-gasnozzle lower part
80	50193201	Gas nozzle conical-ID14mm
81	50193001	Gas nozzle conical-ID16mm
82	50193301	Gas nozzle cylindrical-ID19mm
84	50193361	Narrow-gap gas nozzle with cylinder ID11-AD13-L45mm (overall length 128mm)
Spirals and liners also available in other sizes on inquiry!		
90	20450311	Guide spiral-liner ID2,0-AD4,5 fits 3m / EURO central adapter
90	20450411	Guide spiral-liner ID2,0-AD4,5 fits 4m / EURO central adapter
90	20450511	Guide spiral-liner ID2,0-AD4,5 fits 5m / EURO central adapter
90	25450311	Guide spiral-liner ID2,5-AD4,5 fits 3m / EURO central adapter
90	25450411	Guide spiral-liner ID2,5-AD4,5 fits 4m / EURO central adapter
90	25450511	Guide spiral-liner ID2,5-AD4,5 fits 5m / EURO central adapter
92	20393311	PTFE-carbon core liner ID2,0-AD3,9 fits 3m / EURO central adapter
92	20393411	PTFE-carbon core liner ID2,0-AD3,9 fits 4m / EURO central adapter
92	20393511	PTFE-carbon core liner ID2,0-AD3,9 fits 5m / EURO central adapter
92	27473311	PTFE-carbon core liner ID2,7-AD4,7 fits 3m / EURO central adapter
92	27473411	PTFE-carbon core liner ID2,7-AD4,7 fits 4m / EURO central adapter
92	27473511	PTFE-carbon core liner ID2,7-AD4,7 fits 5m / EURO central adapter
92	20406311	Carbon-PA core liner ID2,0-AD4,0 fits 3m / EURO central adapter
92	20406411	Carbon-PA core liner ID2,0-AD4,0 fits 4m / EURO central adapter
92	20406511	Carbon-PA core liner ID2,0-AD4,0 fits 5m / EURO central adapter
92	23476311	Carbon-PA core liner ID2,3-AD4,7 fits 3m / EURO central adapter
92	23476411	Carbon-PA core liner ID2,3-AD4,7 fits 4m / EURO central adapter
92	23476511	Carbon-PA core liner ID2,3-AD4,7 fits 5m / EURO central adapter
92	29476311	Carbon-PA core liner ID2,9-AD4,7 fits 3m / EURO central adapter
92	29476411	Carbon-PA core liner ID2,9-AD4,7 fits 4m / EURO central adapter
92	29476511	Carbon-PA core liner ID2,9-AD4,7 fits 5m / EURO central adapter
92	20404311	ULTRA-liner (brown) ID2,0-OD4,0 fits 3m / EURO central adapter
92	20404411	ULTRA-liner (brown) ID2,0-OD4,0 fits 4m / EURO central adapter

MHS 501-SUPER

Welding-torch MIG-MAG water-cooled

500A at 100% duty cycle (CO2) - 450A at 100% duty cycle (mixed gas)

Art.-No.		
92	20404511	ULTRA-liner (brown) ID2,0-OD4,0 fits 5m / EURO central adapter
92	23474311	ULTRA-liner (brown) ID2,3-OD4,7 fits 3m / EURO central adapter
92	23474411	ULTRA-liner (brown) ID2,3-OD4,7 fits 4m / EURO central adapter
92	23474511	ULTRA-liner (brown) ID2,3-OD4,7 fits 5m / EURO central adapter
92	29474311	ULTRA-liner (brown) ID2,9-OD4,7 fits 3m / EURO central adapter
92	29474411	ULTRA-liner (brown) ID2,9-OD4,7 fits 4m / EURO central adapter
92	29474511	ULTRA-liner (brown) ID2,9-OD4,7 fits 5m / EURO central adapter
N.i.	20405002	Brass spiral liner (marked blue) ID2,0-OD4,0mm L300mm fits liner OD3,9/4,0mm
N.i.	20405001	Brass spiral liner (marked green) ID2,0-OD4,0mm L300mm fits liner OD4,7mm
N.i.	25405002	Bronze spiral liner (marked blue) ID2,5-OD4,0mm L300mm fits liner OD3,9/4,0mm
N.i.	25405001	Bronze spiral liner (marked green) ID2,5-OD4,0mm L300mm fits liner OD4,7mm
95	91905721	Nipple (brass L-30mm) fits spiral liner EURO central adapter AD4,5mm
96	91906111	Nipple fits core liner EURO central adapter AD3,9/4,0mm
96	91906121	Nipple fits core liner EURO central adapter AD 4,7mm
97	91906131	O-ring ID3,5-W1,5mm fits core liners
N.i.	91906112	Support tube, brass ID4,4 - AD5,0 - L200mm